

# SUNSYSTEM®

## HYGIENIC COMBI TANKS series HYG B

vertical models  
500, 800, 1000, 1500 L

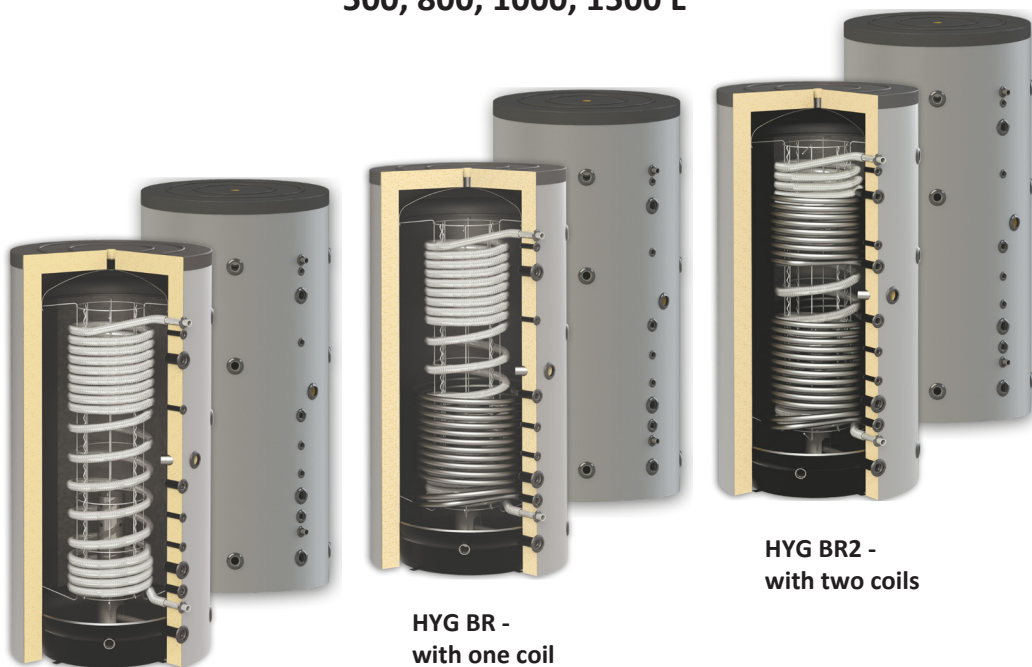

**HYG B**  
without coil

**HYG BR -**  
with one coil

**HYG BR2 -**  
with two coils

## INSTALLATION and OPERATION MANUAL

Version 0.6



**TABLE OF CONTENTS**

<b>1.</b>	<b>INSTRUCTIONS TO INSTALLER .....</b>	<b>4</b>
<b>2.</b>	<b>DESCRIPTION ON HYGIENIC COMBI TANK.....</b>	<b>5</b>
<b>3.</b>	<b>CONNECTING OF RELIEF VALVE TO WATER TANK.....</b>	<b>6</b>
<b>4.</b>	<b>TECHNICAL PARAMETERS TO HYGIENIC COMBI TANK HYG B. ....</b>	<b>7</b>
4.1.	HYG B - without coil.....	7
4.2.	HYG BR - with one coil.....	9
4.3.	HYG BR2 - with two coils.....	11
<b>5.</b>	<b>TRANSPORT AND PACKAGING.....</b>	<b>13</b>
<b>6.</b>	<b>WARRANTY .....</b>	<b>13</b>
<b>7.</b>	<b>RECYCLING .....</b>	<b>15</b>

**Dear Customers,**

We strongly hope that the appliance you have bought from us will contribute to creating comfort at you homes and decreasing the energy expenditure.

This manual contains important information for the safe and correct installation, start-up and trouble-free operation and maintenance of the water heater.

Hygienic Combi Tanks can be used only in the manner described in this manual – to produce and accumulate sanitary hot water and hot water for space-heating system.

The application and any other was the area of operation is not recommended by the manufacturer and is not responsible for the occurrence of defects or failures.

**1. INSTRUCTIONS TO INSTALLER**



**The preparation, installation and commissioning must be performed by an authorized installer / service.**

During installation and operation, the country specific requirements and regulations must be observed:

- local construction regulations on installation of water tank; weight of the boiler to comply with the stability of the floor of the room where it will be installed.
- regulations and norms concerning the fitting of the installation with safety devices.
- safety during installation - personal protective equipment



**Use only original SUNSYSTEM parts.**

**1.1. Requirements to Water Tank installation room**

When choosing a room for tank installation observe the following requirements:

- to have a drainage channel. Some maintenance procedures require draining of all water from the tank.

- Thermal insulation of the room. This provides efficiency of the appliance and prevents the water from freezing.

**1.2. Requirements for installation.**

- The length of connecting pipes between the water tank and consumer must be as short as possible.
- Before connecting the water tank to the installation, check all screw connections (plug and etc.). In very rare cases - during transportation, loading and unloading operations - the screw connections may be loosen.
- Before commissioning, check the installation for leaks
- Do not exceed the working pressure of 3 bar for buffer tank and 6 bar for hygienic stainless steel coil.
- If there is a risk of freezing of water in the tank - drain the tank completely or let the water tank works continuously.

**2. DESCRIPTION ON HYGIENIC COMBI TANK**

Hygienic Combi tanks are used to produce and accumulate sanitary hot water and hot water for space-heating system.

Coil-in-Tank construction - Flexible stainless-steel coil for sanitary hot water + Buffer tank powering space-heating system. Sanitary water heats up instantaneously as it flows through the large surface stainless coil. Thus water is delivered hot while still fresh and clean of depositions.

**HYG-B series** - Inlet/Outlet arrangement – 90 angle degrees.

**HYG-B** models, the heat source is an electric heater.

**HYG-BR** models have a built-in heat exchanger (coil type) designed to connect to a solar installation or boiler. Option for installation of an electric heating element.

**HYG-BR2** models have two built-in heat exchanger (coil type) for connection to the solar system and boiler. Option for installation of an electric heating element.

**2.1. Removable insulation and outer casing.**

The quality of the insulation of a water heater is a key factor for its heat conservation capability and energy efficiency.

All Hygienic Combi tanks HYG series/ HYG-B series have Removable insulation with thickness 100 mm (DIN 4753, part 8) and outer casing of PVC with RAL 9006 color.

**2.2. Water tank.**

Floor standing. Water tank is made of low-carbon steel S235JR, DHW tube of sanitary grade stainless steel -316L, heats up instantaneously.

All threads are internal (see technical parameters).

**2.3. Electric heating element.**

Outlet connection of electric heating element 1 ½“ :

3000W/230V; 4500W/230V;  
6000W/230V; 7500W/400V.



The connection of the electric heating element to the electric power supply must be done by a qualified electricians.

When connect the heating element to the electric network, make sure that it is properly grounded.

**Wiring diagrams**

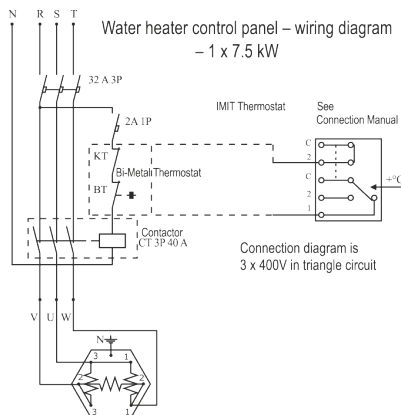
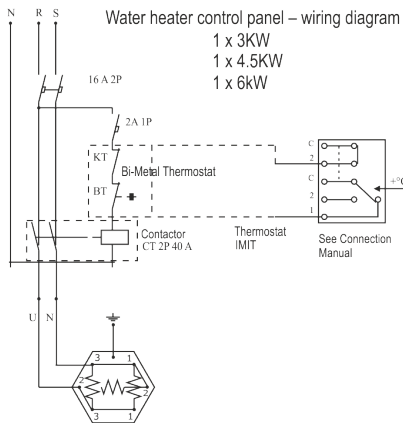
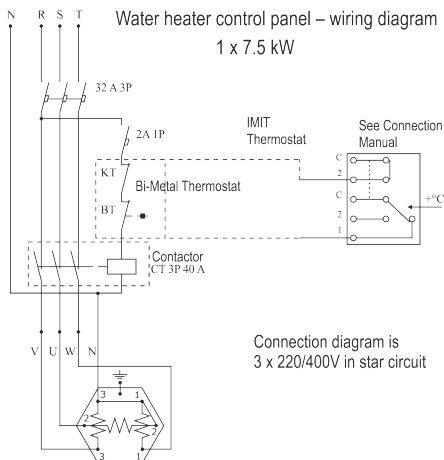

**2.4. Thermostat**

The thermostat may be adjusted by the user within the range 30°C ÷ 80°C, and the thermal protection would go off in case the water reaches 95°C.

This is an adjustable double THERMOSTAT which is designed to regulate the water temperature and ensures safety tolerance; it can be manually adjusted (TLSC model) or automatically adjusted (TLSC/A model).

**3. CONNECTING OF RELIEF VALVE TO WATER TANK**

**3.1. Connecting of Buffer tank.**

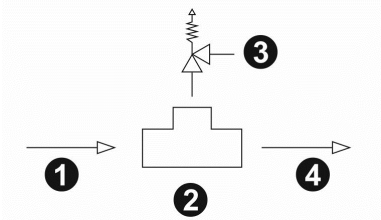

1	Heating system
2	Tee
3	Safety (relief) pressure valve
4	Heat carrier inlet

**3.2. Connecting of Stainless HYG coil.**

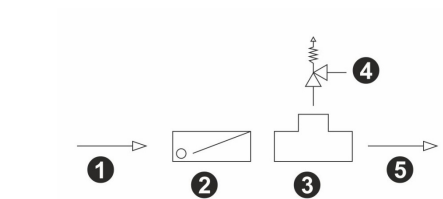

1	Cold water inlet - water supply
2	Check (return) valve
3	Tee
4	Safety (relief) pressure valve
5	Cold water inlet - HYG coil

	<p><b>Stop (Shut-off) valves should never be installed between a safety (relief) valve and the tank. It is recommended once a year to check the operation of the safety valve.</b></p>
---	--

## 4. TECHNICAL PARAMETERS TO HYGIENIC COMBI TANK HYG B

### 4.1. HYG B - without coil



		HYG B 500	HYG B 800	HYG B 1000	HYG B 1500
Capacity	L	500	800	1000	1500
Capacity of water tank DHW / Buffer tank	L1/L2	22/478	25/775	25/975	40/1460
Height without insulation / with insulation	H, Hi, mm	1710/1750	1850/1890	2040/2090	2170/2220
Min. vertical clearance	mm	1720	1865	2074	2262
Diameter without insulation / with insulation	D, mm	∅ 650/850	∅ 790/990	∅ 790/990	∅ 1000/1200
Heat exchange surface	E, m <sup>2</sup>	5.5	6.11	6.11	9.9
Operating pressure / Max. buffer temp	bar/°C	3/95	3/95	3/95	3/95
Operating pressure / Max. DHW tube temp.	bar/°C	6/95	6/95	6/95	6/95
Weight without insulation / with insulation	kg, kg i	119/131	155/171	164/182	266/289
Recommended boiler size, connected to buffer tank	kW	44	75	75	114
Continuous outflow 10/45°C, buffer tank is charged to 65°C	E, 10/45°C, L/h	1080	1840	1840	2800
Continuous outflow 10/38°C, buffer tank is charged to 65°C.	E, 10/38°C, L/h	1350	2300	2300	3500
Single discharge capacity up to 38°C (when the buffer is charged to 65°C)	E, 38°C, L	375	580	790	1150
ΔT -temperature difference between buffer tank and DHW at flow rate 30/40/50 liters/minute..	E, ΔT	6/8/12	3.5/5/8	3.5/5/8	2/3/5
Water stratification unit	∅, mm	∅140	∅140	∅140	∅140
Thermometer	T	option			
Electric Heater		option			

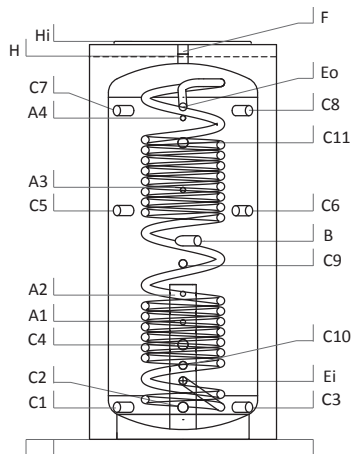

**HYG B  
500 - 1500**

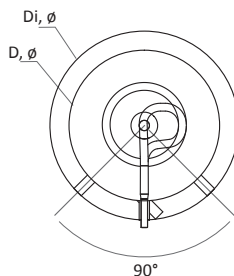

		<b>HYG B 500</b>	<b>HYG B 800</b>	<b>HYG B 1000</b>	<b>HYG B 1500</b>
Boiler heat carrier outlet	C1, mm	500	800	1000	1500
Boiler heat carrier outlet	C2, mm	22/478	25/775	25/975	40/1460
Boiler heat carrier outlet	C3, mm	1710/1750	1850/1890	2040/2090	2170/2220
Boiler heat carrier outlet	C10, mm	1720	1865	2074	2262
Boiler heat carrier	C4, mm	∅ 650/850	∅ 790/990	∅ 790/990	∅ 1000/1200
Boiler heat carrier	C5, mm	5.5	6.11	6.11	9.9
Boiler heat carrier	C6, mm	3/95	3/95	3/95	3/95
Heat carrier inlet	C7, mm	6/95	6/95	6/95	6/95
Heat carrier inlet	C8, mm	119/131	155/171	164/182	266/289
Heat carrier inlet	C9, mm	44	75	75	114
Heat carrier inlet	C11, mm	1080	1840	1840	2800
Sensor sleeve	A1, mm	1350	2300	2300	3500
Sensor sleeve	A2, mm	375	580	790	1150
Sensor sleeve	A3, mm	6/8/12	3.5/5/8	3.5/5/8	2/3/5
Sensor sleeve	A4, mm	∅140	∅140	∅140	∅140
Boiler heat carrier / Electric heating element	B, mm	Rp1 <sup>1/2</sup> "/900	Rp1 <sup>1/2</sup> "/930	Rp1 <sup>1/2</sup> "/1050	Rp1 <sup>1/2</sup> "/1280
Air Vent	F, mm	Rp1 <sup>1/2</sup> "/1700	Rp1 <sup>1/2</sup> "/1840	Rp1 <sup>1/2</sup> "/2040	Rp1 <sup>1/2</sup> "/2170
Inlet/outlet DHW coil (tube)	Ei/Eo, mm Rp1"	250/1480	270/1590	310/1760	345/1850

**4.2. HYG BR - with one coil**

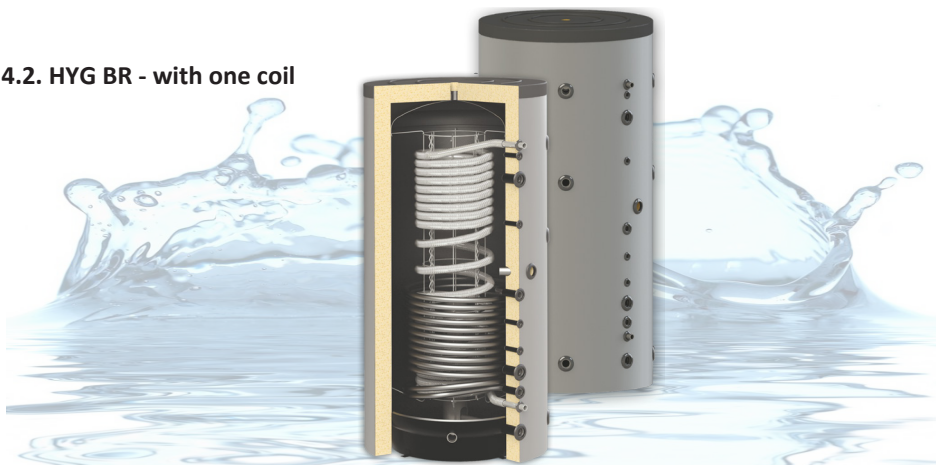

		HYG BR 500	HYG BR 800	HYG BR 1000	HYG BR 1500
Capacity	L	500	800	1000	1500
Capacity of water tank DHW / Buffer tank	L1/L2	22/478	25/775	25/975	40/1460
Height without insulation / with insulation	H, Hi, mm	1710/1750	1850/1890	2040/2090	2170/2220
Min. vertical clearance	mm	1720	1865	2074	2262
Diameter without insulation / with insulation	D, mm	Ø 650/850	Ø 790/990	Ø 790/990	Ø 1000/1200
Heat exchange surface	E, m <sup>2</sup>	5.5	6.11	6.11	9.9
Lower heat exchanger coil S1 Heat exchange surface	S1, m <sup>2</sup>	1.7	2.9	3.0	3.4
Lower heat exchanger coil - capacity S1	L	10.5	17.9	18.5	21.0
Heating power of the lower / upper coil (from an additional heat source)	kW	37	72	75	91
Lower / Upper Productivity 80°C/60°C (from an additional heat source)	L/h	1590	3095	3224	3912
Recommended Absorber Heat exchange surface of Solar Collectors	m <sup>2</sup>	8.00	12.00	14.00	22.00
Operating pressure/Max. coil temperature	bar/°C	16/110	16/110	16/110	16/110
Operating pressure / Max. buffer temp	bar/°C	3/95	3/95	3/95	3/95
Operating pressure / Max. DHW tube temp.	bar/°C	6/95	6/95	6/95	6/95
Weight without insulation / with insulation	kg, kg i	142/154	188/204	210/228	331/354
Recommended boiler size, connected to buffer tank	kW	44	75	75	114
Continuous outflow 10/45°C, buffer tank is charged to 65°C	E, 10/45°C, L/h	1080	1840	1840	2800
Continuous outflow 10/38°C, buffer tank is charged to 65°C	E, 10/38°C, L/h	1350	2300	2300	3500
Single discharge capacity up to 38°C (when the buffer is charged to 65°C)	E,38°C, L	375	580	790	1150
ΔT -temperature difference between buffer tank and DHW at flow rate 30/40/50 liters/minute..	E, ΔT	6/8/12	3.5/5/8	3.5/5/8	2/3/5
Water stratification unit	Ø, mm	Ø140	Ø140	Ø140	Ø140

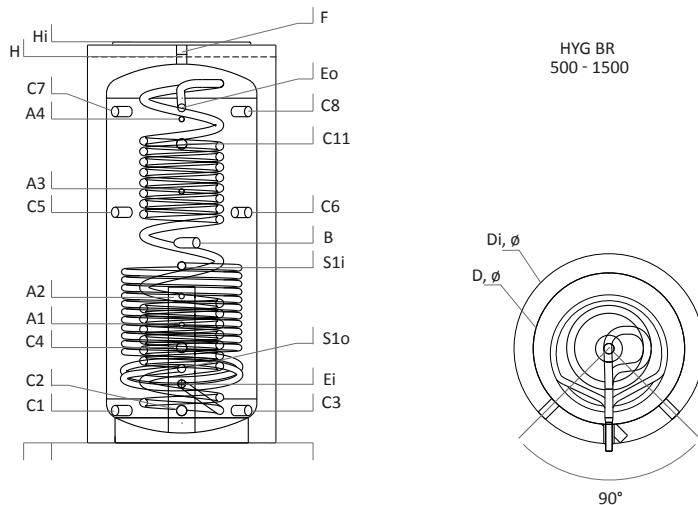

		HYG BR 500	HYG BR 800	HYG BR 1000	HYG BR 1500
Boiler heat carrier outlet	C1, mm	Rp1 <sup>1/2</sup> "/150	Rp1 <sup>1/2</sup> "/170	Rp1 <sup>1/2</sup> "/170	Rp1 <sup>1/2</sup> "/235
Boiler heat carrier outlet	C2, mm	Rp1 <sup>1/2</sup> "/150	Rp1 <sup>1/2</sup> "/170	Rp1 <sup>1/2</sup> "/170	Rp1 <sup>1/2</sup> "/235
Boiler heat carrier outlet	C3, mm	Rp1 <sup>1/2</sup> "/150	Rp1 <sup>1/2</sup> "/170	Rp1 <sup>1/2</sup> "/170	Rp1 <sup>1/2</sup> "/235
Outlet heat carrier/lower coil S1	S1o, mm	Rp1"/325	Rp1"/350	Rp1"/390	Rp1"/445
Boiler heat carrier	C4, mm	Rp1 <sup>1/2</sup> "/430	Rp1 <sup>1/2</sup> "/470	Rp1 <sup>1/2</sup> "/500	Rp1 <sup>1/2</sup> "/690
Boiler heat carrier	C5, mm	Rp1 <sup>1/2</sup> "/1030	Rp1 <sup>1/2</sup> "/1050	Rp1 <sup>1/2</sup> "/1210	Rp1 <sup>1/2</sup> "/1405
Boiler heat carrier	C6, mm	Rp1 <sup>1/2</sup> "/1030	Rp1 <sup>1/2</sup> "/1050	Rp1 <sup>1/2</sup> "/1210	Rp1 <sup>1/2</sup> "/1405
Heat carrier inlet	C7, mm	Rp1 <sup>1/2</sup> "/1450	Rp1 <sup>1/2</sup> "/1550	Rp1 <sup>1/2</sup> "/1740	Rp1 <sup>1/2</sup> "/1820
Heat carrier inlet	C8, mm	Rp1 <sup>1/2</sup> "/1450	Rp1 <sup>1/2</sup> "/1550	Rp1 <sup>1/2</sup> "/1740	Rp1 <sup>1/2</sup> "/1820
Inlet heat carrier/lower coil S1	S1i, mm	Rp1"/775	Rp1"/845	Rp1"/930	Rp1"/1045
Heat carrier inlet	C11, mm	Rp1 <sup>1/2</sup> "/1360	Rp1 <sup>1/2</sup> "/1410	Rp1 <sup>1/2</sup> "/1570	Rp1 <sup>1/2</sup> "/1720
Sensor sleeve	A1, mm	Rp1 <sup>1/2</sup> "/540	Rp1 <sup>1/2</sup> "/590	Rp1 <sup>1/2</sup> "/620	Rp1 <sup>1/2</sup> "/800
Sensor sleeve	A2, mm	Rp1 <sup>1/2</sup> "/650	Rp1 <sup>1/2</sup> "/710	Rp1 <sup>1/2</sup> "/770	Rp1 <sup>1/2</sup> "/920
Sensor sleeve	A3, mm	Rp1 <sup>1/2</sup> "/1140	Rp1 <sup>1/2</sup> "/1160	Rp1 <sup>1/2</sup> "/1320	Rp1 <sup>1/2</sup> "/1520
Sensor sleeve	A4, mm	Rp1 <sup>1/2</sup> "/1420	Rp1 <sup>1/2</sup> "/1520	Rp1 <sup>1/2</sup> "/1700	Rp1 <sup>1/2</sup> "/1790
Boiler heat carrier / Electric heating element	B, mm	Rp1 <sup>1/2</sup> "/900	Rp1 <sup>1/2</sup> "/930	Rp1 <sup>1/2</sup> "/1050	Rp1 <sup>1/2</sup> "/1280
Air Vent	F, mm	Rp1 <sup>1/2</sup> "/1710	Rp1 <sup>1/2</sup> "/1850	Rp1 <sup>1/2</sup> "/2040	Rp1 <sup>1/2</sup> "/2170
Inlet/outlet DHW coil (tube)	Ei/Eo, mm Rp1"	250/1480	270/1580	310/1760	345/1850
Thermometer	T	option			
Electric Heater		option			

**4.3. HYG BR2 - with two coils**



		HYG BR2 500	HYG BR2 800	HYG BR2 1000	HYG BR2 1500
Capacity	L	500	800	1000	1500
Capacity of water tank DHW / Buffer tank	L1/L2	22/478	25/775	25/975	40/1460
Height without insulation / with insulation	H, Hi, mm	1710/1750	1850/1890	2040/2090	2170/2220
Min. vertical clearance	mm	1720	1865	2074	2262
Diameter without insulation / with insulation	D, mm	∅ 650/850	∅ 790/990	∅ 790/990	∅ 1000/1200
Heat exchange surface	E, m <sup>2</sup>	5.5	6.11	6.11	9.9
Heat exchange surface - Lower/Upper coil S1/S2	S1, S2m <sup>2</sup>	1.7/1.0	2.9/1.8	3.0/2.0	3.4/2.4
Capacity Lower/Upper coil S1/S2	L	10.5/6.2	17.9/11.1	18.5/12.3	21.0/14.8
Heating power of the lower / upper coil (from an additional heat source)	kW	37/19	72/39	75/42	91/55
Lower / Upper Productivity 80°C/60°C (from an additional heat source)	L/h	1590/816	3095/1677	3224/1806	3912/2365
Recommended Absorber Heat exchange surface of Solar Collectors	m <sup>2</sup>	8.00	12.00	14.00	22.00
Operating pressure/Max. coil temperature	bar/°C	16/110	16/110	16/110	16/110
Operating pressure / Max. buffer temperature	bar/°C	3/95	3/95	3/95	3/95
Operating pressure / Max. DHW tube temperature.	bar/°C	6/95	6/95	6/95	6/95
Weight without insulation / with insulation	kg, kg i	164/176	213/229	230/248	352/375
Recommended boiler size, connected to buffer tank	kW	44	75	75	114
Continuous outflow 10/45°C, buffer tank is charged to 65°C	E, 10/45°C, L/h	1080	1840	1840	2800
Continuous outflow 10/38°C, buffer tank is charged to 65°C.	E, 10/38°C, L/h	1350	2300	2300	3500
Single discharge capacity up to 38°C (when the buffer is charged to 65°C)	E,38°C, L	375	580	790	1150
ΔT-temperature difference between buffer tank and DHW at flow rate 30/40/50 liters/minute..	E, ΔT	6/8/12	3.5/5/8	3.5/5/8	2/3/5
Water stratification unit	∅, mm	∅140	∅140	∅140	∅140

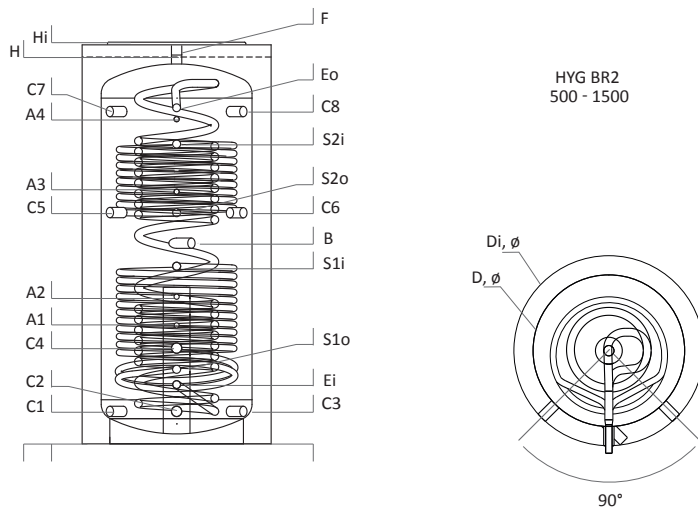

		HYG BR2 500	HYG BR2 800	HYG BR2 1000	HYG BR2 1500
Boiler heat carrier outlet	C1, mm	Rp1 <sup>1/2</sup> "/150	Rp1 <sup>1/2</sup> "/170	Rp1 <sup>1/2</sup> "/170	Rp1 <sup>1/2</sup> "/235
Boiler heat carrier outlet	C2, mm	Rp1 <sup>1/2</sup> "/150	Rp1 <sup>1/2</sup> "/170	Rp1 <sup>1/2</sup> "/170	Rp1 <sup>1/2</sup> "/235
Boiler heat carrier outlet	C3, mm	Rp1 <sup>1/2</sup> "/150	Rp1 <sup>1/2</sup> "/170	Rp1 <sup>1/2</sup> "/170	Rp1 <sup>1/2</sup> "/235
Outlet heat carrier/lower coil S1	S1o, mm	Rp1"/325	Rp1"/350	Rp1"/390	Rp1"/445
Boiler heat carrier	C4, mm	Rp1 <sup>1/2</sup> "/430	Rp1 <sup>1/2</sup> "/470	Rp1 <sup>1/2</sup> "/500	Rp1 <sup>1/2</sup> "/690
Boiler heat carrier	C5, C6mm	Rp1 <sup>1/2</sup> "/1030	Rp1 <sup>1/2</sup> "/1050	Rp1 <sup>1/2</sup> "/1210	Rp1 <sup>1/2</sup> "/1405
Outlet heat carrier/upper coil S2	S2o, mm	Rp1"/1030	Rp1"/1050	Rp1"/1210	Rp1"/1405
Heat carrier inlet	C7, mm	Rp1 <sup>1/2</sup> "/1450	Rp1 <sup>1/2</sup> "/1550	Rp1 <sup>1/2</sup> "/1740	Rp1 <sup>1/2</sup> "/1820
Heat carrier inlet	C8, mm	Rp1 <sup>1/2</sup> "/1450	Rp1 <sup>1/2</sup> "/1550	Rp1 <sup>1/2</sup> "/1740	Rp1 <sup>1/2</sup> "/1820
Inlet heat carrier/lower coil S1	S1i, mm	Rp1"/775	Rp1"/845	Rp1"/930	Rp1"/1045
Inlet heat carrier/upper coil S2	S2i, mm	Rp1"/1360	Rp1"/1410	Rp1"/1570	Rp1"/1720
Sensor sleeve	A1, mm	Rp1 <sup>1/2</sup> "/540	Rp1 <sup>1/2</sup> "/590	Rp1 <sup>1/2</sup> "/620	Rp1 <sup>1/2</sup> "/800
Sensor sleeve	A2, mm	Rp1 <sup>1/2</sup> "/650	Rp1 <sup>1/2</sup> "/710	Rp1 <sup>1/2</sup> "/770	Rp1 <sup>1/2</sup> "/920
Sensor sleeve	A3, mm	Rp1 <sup>1/2</sup> "/1140	Rp1 <sup>1/2</sup> "/1160	Rp1 <sup>1/2</sup> "/1320	Rp1 <sup>1/2</sup> "/1520
Sensor sleeve	A4, mm	Rp1 <sup>1/2</sup> "/1420	Rp1 <sup>1/2</sup> "/1520	Rp1 <sup>1/2</sup> "/1700	Rp1 <sup>1/2</sup> "/1790
Boiler heat carrier / Electric heating element	B, mm	Rp1 <sup>1/2</sup> "/900	Rp1 <sup>1/2</sup> "/930	Rp1 <sup>1/2</sup> "/1050	Rp1 <sup>1/2</sup> "/1280
Air Vent	F, mm	Rp1 <sup>1/2</sup> "/1710	Rp1 <sup>1/2</sup> "/1850	Rp1 <sup>1/2</sup> "/2040	Rp1 <sup>1/2</sup> "/2170
Inlet/outlet DHW coil (tube)	Ei/Eo, mm Rp1"	250/1480	270/1580	310/1760	345/1850
Thermometer	T	option			
Electric Heater		option			

**5. TRANSPORT AND PACKAGING**

We recommend to transport the water tank to the installation site in its packaging placed on the pallet, and stretch foil.

During transport and installation, depending on the weight, appropriate safety equipment must be used in accordance with Directive 2006/42/EC.

When transporting items weighing more than 30 kg, the use of pallet jack, fork truck or other hoisting devices is a must.

Hygienic Combi Tanks can be with or without insulation. They are secured on a pallet packed with foil.

Insulation, decorative cover and rosettes can be delivered separately.

**Advantages:**

- Easy transportation (takes less space at transportation).
- Easy conveyance to the place of installation.
- Easy and quick packing of water heaters with soft insulation. All necessary openings in the casing are made beforehand, and the installer has only to find them and take them out.  
The casing is fastened by a zipper at the assembly platform.

**6. WARRANTY**

**6.1. Manufacturing defects and materials guarantee**

NES Ltd. expressly guarantees that the products it manufactures shall be free from defects in materials and workmanship which can prevent from normal operation under proper and normal use, installation and maintenance for the intended functions of the products, for a period set out in the warranty certificate of the respective water heater model you have bought. The warranty period begins from the date indicated in the purchase invoice. If a product or any component there of is determined to be defective in manufacture or materials, NES Ltd. will repair or replace the defective component or product

**6.2. Exclusions and Limitations of Warranty Coverage**

a) The customer can claim warranty during warranty period of respective product immediately after any defects have been determined, except for in case of noticeable defects at the moment of purchase, in which case the customer must make the claim at the shop immediately after noticing the defect as it is provided for in the general conditions of sale.

- 1) Accidents, installation on movable structures, negligence, improper care or nonconformity.
- 2) Failure to observe the installation, use and maintenance instructions set forth in the installation manual of respective product.
- 3) Improper installation and use as well as changes, especially if they are not made by authorized after-sale service personnel of NES Ltd.
- 4) Testing and operation pressures greater than

Pallet Dimensions	Capacity of Water tank, L			
	500	800	1000	1500
Without insulation, mm	700 x 810	800 x 950	800 X 950	1050 x 1160
With insulation, mm	700 x 810	800 x 950	800 X 950	1050 x 1160

values established by NES Ltd. and set forth in product manuals, or use of water with characteristic values exceeding:

- Dissolvable salts – 500 mg/l;
- Calcium carbonate – 200 mg/l;
- Free carbon dioxide – 50 mg/l;
- ph content – minimum 5 and maximum 12.

5) Freeze, flood, natural disasters or third party actions as well as any interventions into normal functioning conditions of water heaters and the control of NES Ltd.

The customer as well should monitor the anticorrosion system (magnesium anode). He should periodically check the magnesium anode and replace it depending on the geographic location at intervals depending on the type of water (soft of hard) of the region where the water heater is being used.

b) The warranty certificate is considered void for water heaters whose serial identification number has been modified, removed or blurred, or cannot be expressly attested.

c) Damages in the appearance of products shall not be considered as defects except for those ones which cause losses during operation or change technical characteristics of water heaters set forth in brochures.

d) NES Ltd. preserves the right, in case of replacement, to deliver another model of water heater in order to fulfill approved warranty claims when the original model is not being manufactured.

### 6.3. Claiming warranty

Every customer who has purchased a water heater from NES Ltd., and who has good reasons to lay a warranty claim, shall proceed as follows:

a) Immediately notify in writing:

- 1) The installer, or the company that has sold the water heater to him, or
- 2) The distributor firm, or
- 3) The commercial representative of NES Ltd. in the region.

For this purpose the claimant shall fill out a claim form; the latter shall be accompanied by the document proving the purchase of the water heater (invoice) with the date of purchase

in it.

b) After receiving the claim form, NES Ltd. considers it and makes decision whether the claim has grounds, and whether the defect is within the scope of the warranty set forth in this certificate for limited warranty; after which informs the customer as to its decision and the steps he shall do.

c) The return of a product cannot be done without written authorization issued by the Quality Department. The return procedure shall be according to RMA (Return Material Authorization).

d) If on customer's request, and when there is reason for urgency, the customer demands immediate replacement of the product he has claimed warranty for, before making the decision as to the claim, said request shall be accompanied by a Purchase requisition from the Commercial Department. After decision for satisfaction of the claim has been made, the Purchase requisition mentioned above will be annulled by issuing a receipt for returned goods; with this receipt the customer can purchase another product with the same price in case the claim has proved grounded.

e) NES Ltd. reserves the right to make in situ reports from the claims they have received for the purpose of checking every aspect that might be useful for better consideration of warranty claims; for this reason the customer shall not make any changes in installation conditions which are reasons for the claim without prior written consent of the Technical Department.

### 6.4. Limitation of liability

a) NES Ltd. is not liable before the customer, neither directly nor indirectly, for any non-fulfillment or delay at applying the warranty obligations which might originate from external pressure of other circumstances outside NES Ltd

b) The liability of NES Ltd. under this

Warranty Certificate is limited to the above-mentioned obligations and up to the sum in accordance with the purchase receipt of the product to be claimed; excluded is any liability for indirect damages such as loss of data at information applications, loss of production, thermal variations at the service, etc. which do not violate the applicable regulations of any country concerning product liability.

c) Abovementioned warranty limitations will be applied in any cases, and when they do not violate the regulations in any country concerning product liability. If this circumstance annuls some of preceding clauses, annulment will refer only to this clause, while the others will remain valid. In conclusion, excluded is application of any Regulation pointed out in this Warranty which violates the Law 23/July 10, 2003 and Directive 1999/44/EU concerning water heaters and their use on the territory of the EU.

d) Any other warranty right that is not mentioned in this Warranty Certificate is excluded.

## 7. RECYCLING AND WASTE DISPOSAL

Submit all packaging material for recycling according to the local regulations and requirements.

At the end of life cycle of each product its components are due to be disposed of in conformity with regulatory prescriptions.

According to Directive 2002/96/EC regarding electrical and electronic equipment waste, disposal thereof is required separately from the normal flow of solid household waste. Obsolete equipment shall be collected separately from other recyclable waste containing materials with adverse effect on health and environment.

Expired appliances must be collected separately from other recyclable waste containing substances hazardous to health and environment.

Both metal and non-metal parts are sold out to licensed organizations for recyclable metal or non-metal waste collection. In any case they should not be treated as household waste.





**NES**  
**new energy systems**

tel.: +359 700 17 343

[www.burnit.bg](http://www.burnit.bg)